

---

# Table of Contents

## Emissions Overview

Subject	Page
<b>Emissions Overview</b> .....	<b>3</b>
Purpose of the System .....	3
What is OBD? .....	3
What is the most common problem detected by OBD? .....	4
Fuel Filler Cap .....	4
Misfire Detection .....	4
<b>Engine Misfire Diagnosis</b> .....	<b>5</b>
<b>OBD History</b> .....	<b>8</b>
OBD I .....	9
OBD II .....	9
Objectives of OBD II .....	9
<b>Overview of the National Low Emission Vehicle Program</b> .....	<b>10</b>
Emission Reduction Stages .....	10
SULEV .....	12
M56 Engine .....	12
Catalytic Converters .....	12
Oxygen Sensors .....	12
Fuel Injectors .....	13
Secondary Air System .....	14
Fuel System .....	15
Cooling System .....	16
<b>System Monitoring</b> .....	<b>17</b>
Permanent Monitoring .....	17
Cyclic Monitoring .....	17
Drive Cycle .....	18
Example of a Drive Cycle for Completing all OBD II Relevant Checks .....	18
<b>Readiness Code</b> .....	<b>21</b>
Readiness Code using the DISplus/GT-1 .....	22
<b>OBD II Diagnostic Trouble Codes (DTC)</b> .....	<b>23</b>
<b>Scan Tool Connection</b> .....	<b>24</b>
20 Pin Diagnostic Socket Deletion .....	25
<b>BMW Fault Code (DISplus/GT-1)</b> .....	<b>27</b>
OBD II Fault Memory and Fault Codes .....	28
Emission Control Function Monitoring & Comprehensive Component Monitoring .....	28

---

# Emissions Overview

**Model: All Equipped with OBD II**

**Production: 1995 to Present**

**Manufacturer: Bosch and Siemens Engine Control Modules**

**Pin Connector: 88 and 134 Pins**

# OBJECTIVES

After completion of this module you will be able to:

- Describe What is Required to Illuminate the “Malfunction Indicator” Light.
- Describe The Difference Between TLEV, LEV ,ULEV, and SULEV.  
(SULEV - See Service Bulletin at the end of module.)
- Identify Vehicle Emission Compliance by Production Date.
- List the Systems/Components that are Permanently Monitored.
- Access the Readiness Codes using the DISplus/GT-1.
- Find the DLC Connector Locations in Various BMW Vehicles.

---

## Emissions Overview

### Purpose of the System

#### What is OBD?

Today many of the engine's control systems such as throttle opening, fuel injection, ignition, emissions and performance are controlled by an electronic control module and the related sensors and actuators. The first on-board diagnostic (OBD) systems were developed by the manufacturer as a way to detect problems with the electronic systems.

Beginning with 1994 model year, requirements for OBD systems have been established by the EPA and CARB. The purpose of the OBD system is to assure proper emission control system operation for the vehicle's lifetime by monitoring emission-related components and systems for deterioration and malfunction. This includes also a check of the tank ventilation system for vapor leaks.

The OBD system consists of the engine and transmission control modules, their sensors and actuators along with the diagnostic software. The control modules can detect system problems even before the driver notices a driveability problem because many problems that affect emissions can be electrical or even chemical in nature.

#### What happens if a problem is detected?

When the OBD system determines that a problem exists, a corresponding "Diagnostic Trouble Code" is stored in the control module's memory.

The control module also illuminates a yellow dashboard Malfunction Indicator Light indicating "Check Engine" or "Service Engine Soon" or displays an engine symbol.



This light informs the driver of the need for service, NOT of the need to stop the vehicle. A blinking or flashing dashboard light indicates a rather severe level of engine misfire.

After fixing the problem the Fault code is deleted to turn off the light. If the conditions that caused a problem are no longer present the vehicle's OBD system can turn off the dashboard light automatically. If the OBD system evaluates the component or system three consecutive times and no longer detects the initial problem, the dashboard light will turn off automatically.

---

## What is the most common problem detected by OBD?

### Fuel Filler Cap

If the fuel filler cap is not properly closed after refueling, the OBD system will detect the vapor leak that exists from the cap not being completely tightened.

If you tighten the cap subsequently, the dashboard light should be extinguished within a few days or after deleting the Fault code. This is not an indication of a faulty OBD system. The OBD system has properly diagnosed the problem and accordingly alerted the driver by illuminating the dashboard light.

Please check the fuel filler cap first when the dashboard light comes on to avoid unnecessary diagnostic time. To check the fuel filler cap turn the cap to the right until you hear a click or the cap reaches the full stop. Make sure that the retaining strap is not caught between the filler pipe and the fuel filler cap. If the light should stay on further in depth evaporative leak diagnosis is required.

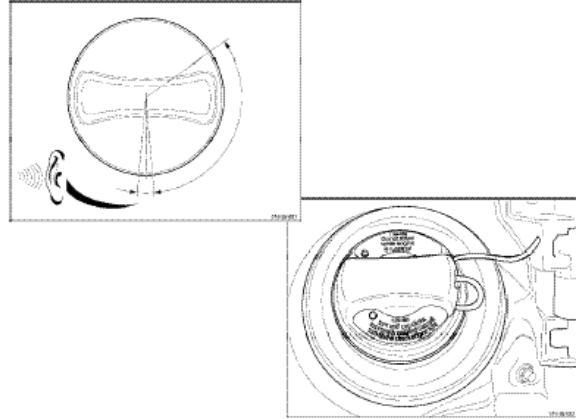

### Misfire Detection

As part of the CARB/OBD II regulations the Engine Control Module must determine if misfire is occurring and also identify the specific cylinder(s). The ECM will determine severity of the misfire event, and whether it is emissions relevant or catalyst damaging. In order to accomplish these tasks the ECM monitors the crankshaft for acceleration losses during firing segments of cylinder specific firing order. If the signal is implausible an erroneous reference mark can be obtained by the ECM which will result in a misfire fault being set.

Possible causes of cylinder misfire faults (actual field findings):

- Vehicle ran low or out of fuel
- Poor fuel quality (ex. water in fuel, customer uses an additive, etc.)
- Low/high fuel pressure
- Ignition coil
- Fouled spark plug(s)
- Restricted / contaminated fuel injector(s)
- Crankshaft position sensor
- Poor combustion due to low compression or high leakage
- Blocked/restricted Catalyst

# Engine Misfire Diagnosis

Engine Misfire is the result of inefficient combustion in one or more cylinders. The causes of Engine Misfire are extensive but can be grouped into the following sub-systems. Consider the charts below as an additional diagnostic aid once the DISplus/GT-1 is connected, the correct fault symptom has been chosen and the fault memory has been interrogated. Follow the Test Module as displayed by the DISplus/GT-1.

IGNITION SYSTEM			
COMPONENT	POSSIBLE CONDITION	TEST	CORRECTION
<b>Spark Plug:</b>	<ul style="list-style-type: none"> <li>• Incorrect spark plug installed</li> <li>• Electrode gap closed or too small</li> <li>• Electrode(s) missing</li> <li>• Oil or fuel fouled spark plug</li> <li>• Ceramic insulation cracked</li> </ul>	Secondary Ignition DISplus Preset Measurement	<ul style="list-style-type: none"> <li>• Verify correct spark plug</li> <li>• Replace if necessary</li> <li>• Swap with another cylinder</li> </ul>
<b>Secondary circuit: (wiring, M73-cap, rotor)</b>	<ul style="list-style-type: none"> <li>• Wet or moist due to water infiltration.</li> <li>• High resistance due to corrosion.</li> </ul>		<ul style="list-style-type: none"> <li>• Check water ingress, repair, replace</li> <li>• Check resistance value, replace</li> </ul>
<b>Ignition Coil(s):</b>	<ul style="list-style-type: none"> <li>• Secondary/Primary Circuits open or shorted.</li> <li>• Housing cracked, damaged.</li> </ul>	Secondary and Primary	<ul style="list-style-type: none"> <li>• Inspect and replace if necessary</li> <li>• Swap with another cylinder</li> </ul>
<b>Ignition Coil &amp; Engine Harness Connectors</b>	<ul style="list-style-type: none"> <li>• Power supply, Primary control and ground (shunt signal) circuits impaired.</li> </ul>	Primary Ignition & Term 4A feed-back Preset Measurements	<ul style="list-style-type: none"> <li>• Look for open, loose connector, corrosion, crossed or backed out pins (also consider ignition unloader or ECM relay on MY97 and newer cars).</li> <li>• Determine defective condition, repair or replace.</li> </ul>

- A secondary ignition oscilloscope display provides vital information about the ignition system's condition.
- Follow the precautions in group 12 of the Repair Instructions.
- Use the following scope patterns as a guideline for ignition system diagnosis. Use the preset measurement function of DISplus.

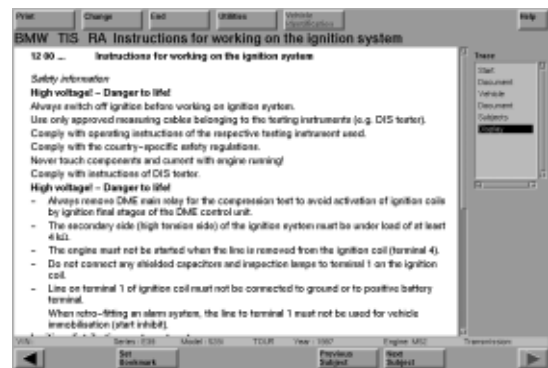

Evaluation of secondary signal amplitude at idle speed.

1. Normal Ignition Voltage Peak: **Spark Plug is OK**
2. Low Ignition Voltage Peak: **Gap too small (defective)**
3. High Ignition voltage peak: **Gap too large (defective)**

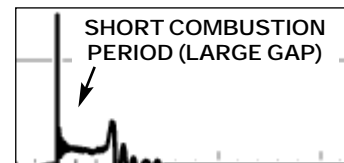
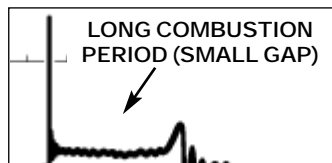
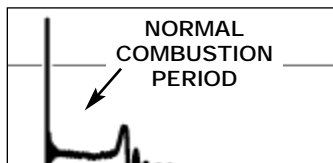
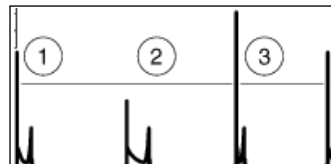

## ENGINE MECHANICAL SYSTEMS

COMPONENT	POSSIBLE CONDITION	TEST	CORRECTION
<b>Pistons, Rings, Valves, Camshaft:</b>	<ul style="list-style-type: none"> <li>Hole in piston crown, ring(s) broken, valve(s) not seating, valve(s) bent, valve spring(s) broken, camshaft lobe cracked, etc.</li> </ul>	<ul style="list-style-type: none"> <li>Idle Quality - Rough Running Preset.</li> <li>Cylinder compression &amp; leakdown tests.</li> </ul>	<ul style="list-style-type: none"> <li>Correct condition as required.</li> </ul>
<b>Hydraulic Valve Actuator (HVA):</b>	<ul style="list-style-type: none"> <li>HVA oil bore restricted or blocked.</li> <li>Engine oil pressure builds up too slow.</li> <li><b>Intermittent Misfire Fault</b> - Not Currently Present.</li> <li>HVA binding/sticking in bore.</li> </ul>	<ul style="list-style-type: none"> <li>Idle Quality - Rough Running Preset.</li> <li>Listen to HVA</li> <li>Check Oil Pressure</li> <li>Cylinder leakdown</li> </ul>	<ul style="list-style-type: none"> <li>Always consider mechanical components when diagnosing misfire.</li> <li>Inspect for scoring.</li> </ul>
<b>Vacuum Leaks:</b>	<ul style="list-style-type: none"> <li>Unmetered vacuum leaks causing a "lean" operating condition. Possible "Excessive Mixture Deviation" fault codes.</li> </ul>	<ul style="list-style-type: none"> <li>Idle Quality - Rough Running Preset. Test for vacuum leaks per Repair Instr. and SIB on "Crankcase Ventilation".</li> <li>Interpret Add. &amp; Multiple adaptation values</li> </ul>	<ul style="list-style-type: none"> <li>Correct condition as required.</li> </ul>

## FUEL QUALITY, DELIVERY, INJECTION & EVAPORATIVE SYSTEMS

COMPONENT	POSSIBLE CONDITION	TEST	CORRECTION
<b>Fuel (quality):</b>	<ul style="list-style-type: none"> <li>Contaminated fuel. (water, other non combustible).</li> </ul>		<ul style="list-style-type: none"> <li>Clean fuel system, replace fuel.</li> </ul>
<b>Fuel Delivery:</b>	<ul style="list-style-type: none"> <li>Fuel pump delivery pressure low, restriction in fuel line to fuel rail or running loss valve.</li> <li>Fuel filter restricted (clogged).</li> <li>Low fuel in tank.</li> </ul>	<ul style="list-style-type: none"> <li>Check fuel pressure &amp; volume.</li> <li>Check fuel pump power and ground</li> </ul>	<ul style="list-style-type: none"> <li>Determine restriction/flow reduction, replace component as necessary.</li> <li>Interpret Additive and Multiplicative adaptation values.</li> </ul>
<b>Running Loss Valve:</b>	<ul style="list-style-type: none"> <li>Valve stuck in "small circuit" position.</li> </ul>	<ul style="list-style-type: none"> <li>Check valve</li> </ul>	<ul style="list-style-type: none"> <li>Display "diagnosis requests" in DISplus and test valve for proper function, replace valve as necessary.</li> </ul>
<b>Fuel Injectors:</b>	<ul style="list-style-type: none"> <li>Leaking fuel injector pintle seats cause rich engine starts with hot ambient temperatures.</li> <li>Blocked (dirty) injector(s).</li> </ul>	<ul style="list-style-type: none"> <li>Ti Preset &amp; status page.</li> <li>Sec Ign scope pattern.</li> </ul>	<ul style="list-style-type: none"> <li>Check injectors for leakage.</li> <li>Swap suspect injector with another cylinder.</li> <li>Inspect injector, replace if necessary.</li> </ul>
<b>Fuel Pressure Regulator:</b>	<ul style="list-style-type: none"> <li>Regulator defective, causes fluctuation in the injected quantity of fuel causing mixture adaptation faults.</li> </ul>	<ul style="list-style-type: none"> <li>Fuel pressure</li> </ul>	<ul style="list-style-type: none"> <li>Check nominal fuel pressure value with engine operating under varied speeds.</li> </ul>
<b>Evaporative System:</b>	<ul style="list-style-type: none"> <li>Defective evaporative system vent causing fuel tank collapse and fuel starvation.</li> </ul>	<ul style="list-style-type: none"> <li>DISplus status, Evap test with pressure tool, purge valve func. test.</li> </ul>	<ul style="list-style-type: none"> <li>Check the fuel tank condition and vent line.</li> <li>Check Fresh Air Valve on TLEV E36 vehicles or LDP/DM TL and filter on ORVR vehicles for proper system "breathing".</li> </ul>

## IMPLAUSIBLE ECM CONTROL FUNCTION OR SENSOR INPUT SIG-

COMPONENT	POSSIBLE CONDITION	TEST	CORRECTION
<b>Crankshaft Position Sensor or Increment Wheel:</b>	<ul style="list-style-type: none"> <li>• Implausible signal for misfire detection.</li> <li>• Increment wheel loose or damaged (internal on M44, M52 and M54, external on M62 &amp; M73).</li> <li>• Air gap between sensor and wheel.</li> <li>• Noticeable at higher rpm.</li> </ul>	<ul style="list-style-type: none"> <li>• DISplus preset measurement.</li> </ul>	<ul style="list-style-type: none"> <li>• Determine defective sensor or increment wheel and replace.</li> </ul>
<b>Catalyst Damaged:</b>	<ul style="list-style-type: none"> <li>• Excessive exhaust back pressure (bank specific fault present, more noticeable under heavy load and high rpm).</li> </ul>	<ul style="list-style-type: none"> <li>• DISplus preset measurement of oxygen sensor.</li> <li>• Back pressure test per SIB with Special Tool.</li> </ul>	<ul style="list-style-type: none"> <li>• Determine catalyst condition, replace or repair as necessary.</li> </ul>
<b>Oxygen Sensor:</b>	<ul style="list-style-type: none"> <li>• Excessive mixture deviation, <b>possible vacuum leaks.</b></li> </ul>	<ul style="list-style-type: none"> <li>• Monitor oxygen sensor signal via DIS preset.</li> </ul>	<ul style="list-style-type: none"> <li>• Swap sensor from other bank (if applicable) and see if fault transfers to other bank.</li> </ul>
<b>Engine Control Module</b>	<ul style="list-style-type: none"> <li>• Internal control module fault.</li> <li>• Misfire Reprogramming.</li> </ul>	<ul style="list-style-type: none"> <li>• Check fault memory.</li> <li>• Refer to SIB</li> </ul>	<ul style="list-style-type: none"> <li>• Highly unlikely but must be considered.</li> <li>• Check Model/Prod range - reprogram</li> </ul>

***When diagnosing a Misfire fault code, Remember:***

**“Misfire” is caused by a defect in the internal combustion engine or a defect in the control of the engine operation.**

**“Misfire” is the result of improper combustion (variation between cylinders) as measured at the crankshaft due to:**

- Engine mechanical defects; breakage, wear, leakage or improper tolerances.
- Excessive mixture deviation; air (vacuum leaks), fuel and all the components that deliver air/fuel into the combustion chambers.
- Faulty ignition; primary, secondary including spark plugs.
- Faulty exhaust flow; affecting back pressure.
- Tolerance parameters; ECM programming.

**A Misfire fault code(s) is the “symptom” of a faulty input for proper combustion. When diagnosing a misfire, review the charts to assist you in finding the faulty input.**

---

## OBD History

As a result of low fuel costs, together with a high standard of living and a dense population, the state of California was affected particularly heavily by air pollution. This spurred the state to pass the most comprehensive and stringent emissions and consumption laws in the world. The automobile manufacturers were reminded of their obligations and this drove them on to comply with the new regulations at enormous expense.

- In continuing efforts to improve air quality, the Environmental Protection Agency (EPA) amended the Clean Air Act in 1990. The Clean Air Act was originally mandated in 1970. The Clean Air Act has a direct impact on automobile manufacturers whereby they are responsible to comply with the regulations set forth by the EPA. The 1990 amendment of the Clean Air Act set forth all of the changes currently being introduced on vehicles sold in the United States today.
- In 1967, the State of California formed the California Air Resources Board (CARB) to develop and carry out air quality improvement programs for California's unique air pollution conditions. Through the years, CARB programs have evolved into what we now know as On Board Diagnostics and the National Low Emission Vehicle Program.
- The EPA has adopted many of the CARB programs as National programs and laws. One of these earlier programs was OBD I and the introduction of the "Check Engine" Light.
- BMW first introduced OBD I and the check engine light in the 1987 model year. This enhanced diagnosis through the display of "flash codes" using the check engine light as well as the BMW 2013 and GT-1. OBD I was only the first step in an ongoing effort to monitor and reduce tailpipe emissions.
- By the 1989 model year all automotive manufacturers had to assure that all individual components influencing the composition of exhaust emissions would be electrically monitored and that the driver be informed whenever such a component failed.
- Since the 1996 model year all vehicles must comply with OBD II requirements. OBD II requires the monitoring of virtually every component that can affect the emission performance of a vehicle plus store the associated fault code and condition in memory.

If a problem is detected and then re-detected during a later drive cycle more than one time, the OBD II system must also illuminate the "Check Engine" Light in the instrument cluster to alert the driver that a malfunction has occurred. **However, the flash code function of the Check Engine Light in OBD I vehicles is not a function in OBD II vehicles.**



- 
- This requirement is carried out by the Engine Control Module (ECM/DME) as well as the Automatic Transmission Control Module (EGS/AGS) and the Electronic Throttle Control Module (EML) to monitor and store faults associated with all components/systems that can influence exhaust and evaporative emissions.

## OBD I

The essential elements here are that electrical components which affect exhaust emissions are monitored by the motor-electronics system and an optical warning signal (CHECK ENGINE Light) is issued in the event of an OBD I-relevant malfunction. The corresponding fault can be read out via a flashing code without the aid of a testing device.

## OBD II

Since January 1996, OBD II has been compulsory on all vehicles in the US market. The main difference from OBD I is that not only are the purely electrical components monitored but also all the systems and processes that affect exhaust emissions and fuel system evaporative emissions.

The operational reliability of the exhaust-treatment system must be guaranteed for 5 years and/or 100,000 miles; this is maintained by emission certification. In this case, the data relevant to exhaust/evaporative emissions are read out via a standardized interface with a universal "diagnosis device". If a violation is identified, the vehicle manufacturer in question is legally bound to eliminate the fault throughout the entire vehicle series.

## Objectives of OBD II

- Permanent monitoring of components relevant to exhaust emissions in all vehicles.
- Immediate detection and indication of significant emission increases over the entire service life of each vehicle.
- Permanently low exhaust emissions in the field.

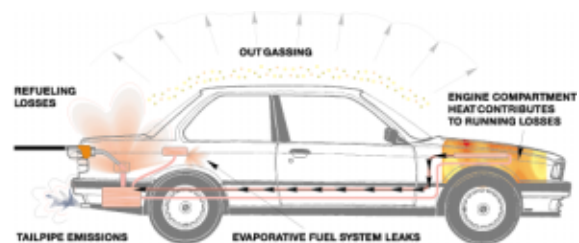

# Overview of the National Low Emission Vehicle Program

## Emission Reduction Stages

While OBD II has the function of monitoring for emission related faults and alerting the operator of the vehicle, the National Low Emission Vehicle Program requires a certain number of vehicles produced (specific to manufacturing totals) **currently** comply with the following emission stages;

**TLEV:** Transitional Low Emission Vehicle

**LEV:** Low Emission Vehicle

**ULEV:** Ultra Low Emission Vehicle.

Prior to the National Low Emission Vehicle Program, the most stringent exhaust reduction compliancy is what is known internally within BMW as HC II. The benefit of exhaust emission reductions that the National Low Emission Vehicle Program provides compared with the HC II standard is as follows;

**TLEV:** 50% cleaner.

**LEV:** 70% cleaner.

**ULEV:** 84% cleaner.

Grams per Mile @ 50° F - Cold Engine Startup			
Compliance Level	NMHC Non Methane Hydrocarbon	CO Carbon Monoxide	NOx Oxide(s) of Nitrogen
TLEV	0.250	3.4	0.4
LEV	0.131	3.4	0.2
ULEV	0.040	1.7	0.2

Grams/Mile at 50,000 miles			
Compliance Level	NMHC Non Methane Hydrocarbon	CO Carbon Monoxide	NOx Oxide(s) of Nitrogen
TLEV	0.125	3.4	0.4
LEV	0.075	3.4	0.2
ULEV	0.040	1.7	0.2

Grams/Mile at 100,000 miles			
Compliance Level	NMHC Non Methane Hydrocarbon	CO Carbon Monoxide	NOx Oxide(s) of Nitrogen
TLEV	0.156	4.2	0.6
LEV	0.090	4.2	0.3
ULEV	0.055	2.1	0.3

## OBD II Emission Compliance

	1995	1996	1997	1998	1999	2000	2001
M44 E36		HC II	TLEV				
		1/96	1/97				
M44 Z3		HC II	TLEV				
		10/96	1/97				
M52 E36		TLEV					
		10/95					
M52TU Z3			TLEV		LEV		
			1/97	9/98 - M52TU			
S52, E36, M3 Mcoupe, Mroadster				TLEV			
				9/98			
M54 Z3						2.5 LEV	3.0 ULEV
							10/00
M52TU E46				LEV			
				6/98			
M54 E46						2.5/3.0xi LEV 9/00	3.0 ULEV 6/00
S54 M3 Mcoupe, Mroadster						LEV	
							1/01
M52TU E39			TLEV		LEV		
		3/96	9/98 - M52TU				
M54 E39						2.5 LEV	3.0 ULEV
							9/00
M62TU E38 E39		HC II		LEV			
		1/96	9/98 - M62TU				
M62TU E53					LEV	LEV - Truck	
					9/99	4/00	
M54 3.0 E53						ULEV-Truck	
							4/00
S62 M5 Z8					TLEV		
					9/99		
M73TU E38		HC II		LEV			
		1/95	9/98 - M73TU				

---

## SULEV

M56 SULEV (Super Ultra Low Emission Vehicle) is available on a limited (by state) basis in the E46/2, E46/3 and E46/4. SULEV models (E46 sedan, coupe and sportwagon all with automatic only) will be sold in California, New York and Massachusetts as 2003 models and in Vermont starting in 2004 model year.

In addition these vehicles are certified as PZEV (Partial Zero Emissions Vehicles).

PZEV regulations include:

- Vehicles must meet SULEV tailpipe emissions standard (approx. 1/5 of ULEV standards)
- Vehicles conform to Zero Evaporative Emissions
- Vehicles subject to extended OBD regulations.
- Emission relevant components warranted for 15 years or 150,000 miles

### M56 Engine

The following components are used to achieve SULEV and Zero Evaporative Emission requirements:

- Pistons Revised to change spark travel path
- Catalytic Converters Ceramic carriers with high cell density for better “Warm Up” Control
- Oxygen Sensors Planar wide band O2 sensors in front of the cats
- Vanos Positioning changed during start up for improved start up and emissions
- Fuel Pump Control Revised with raised pressure and more accurate flow control
- Fuel Injectors New design for improved fuel flow and higher working pressure
- Fuel System All metal fuel system components made of stainless steel
- Air Intake System Revised to block HC escape
- Crankcase Ventilation Revised
- Secondary Air System Mass air flow sensor to monitor secondary air flow
- Cooling System Revised to reduce Ozone levels

### Catalytic Converters

The catalysts attached in direct proximity to the engine and are equipped with ceramic(s) carriers in high cell density technology. These converters reach operating temperature faster and offer quicker control of exhaust emissions. Vehicles are also equipped with dual downstream converters.

### Oxygen Sensors

The M56 engine use for Oxygen sensors, two planar broadband sensors upstream of the converter and two sensors downstream.

The planar broadband sensor reach operating temperature very fast and are able to effect fuel mixtures in approximately 5 seconds.

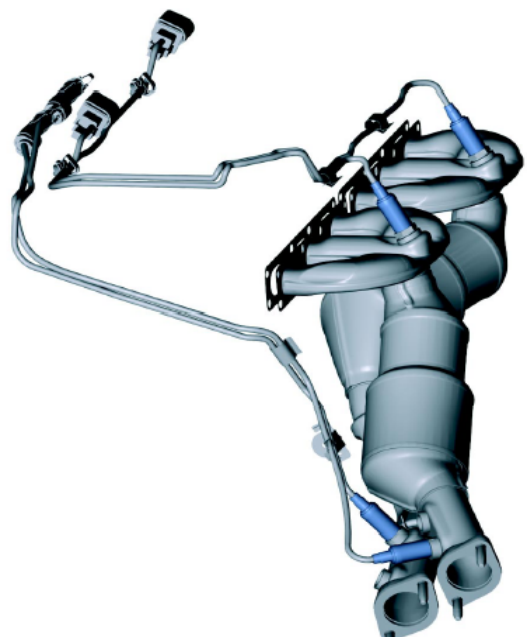

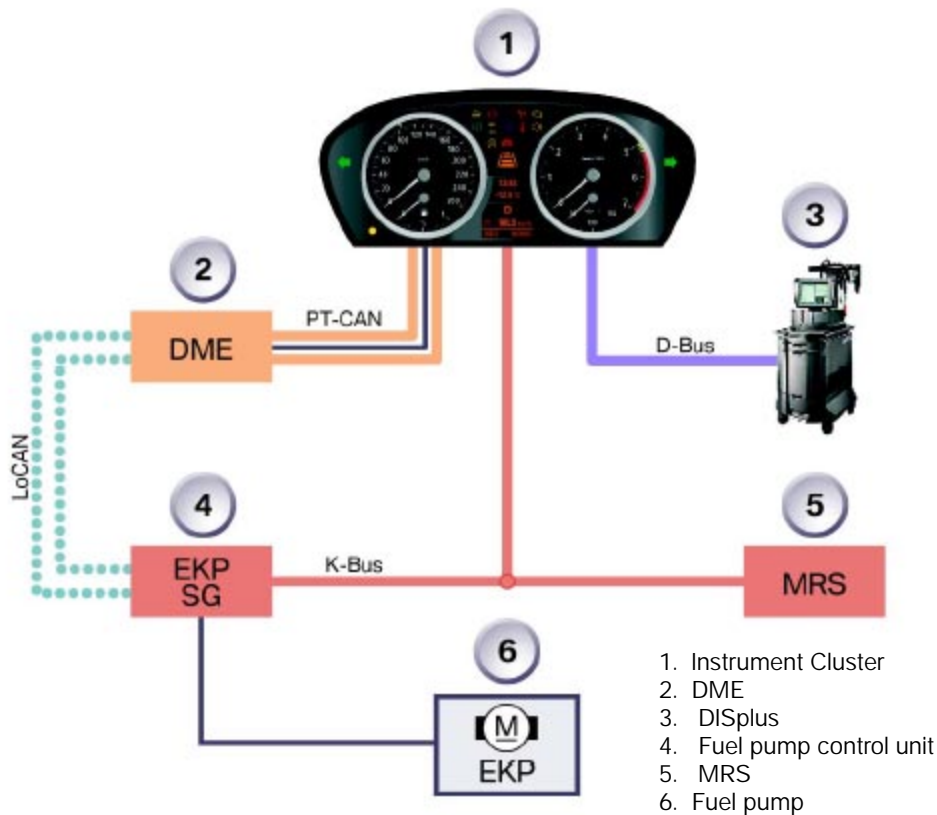

11402

## Fuel Pump System

Fuel system operating pressure is increased to 5 Bar.

The fuel pump is controlled by the Fuel pump control unit, based on engine demand as received from the DME over the Lo-CAN. The fuel pump control unit additionally receives information over the K-Bus, specifically crash information from the MRS.

## Fuel Injectors

Nozzle diameter of the fuel injectors has been reduced and the installation angle has been changed. The injectors were also adapted to perform at the higher system operating pressure.

Injectors screw into the rail and a tap to test pressure readings is **NOT** provided.

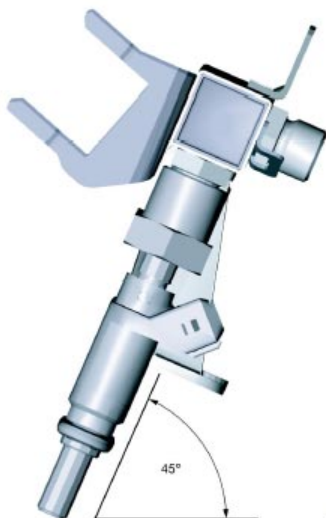

02713\_J

## Secondary Air System



The secondary air pump has been revised to improve its response time in cold weather starting situations.

A HFM (Hot Film Air Mass Meter) has been added to the secondary air system to monitor air volume pumped into the exhaust for more accurate control of the NOx emissions.

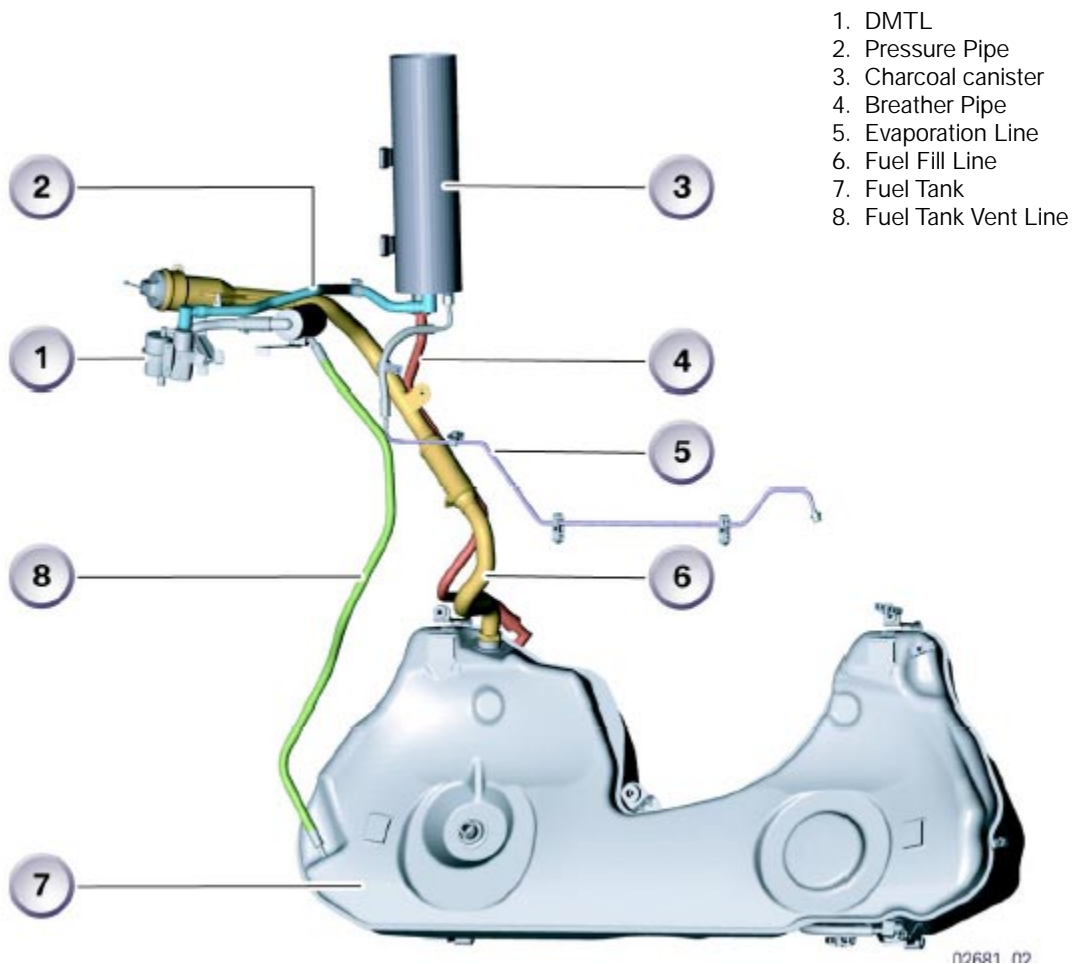

1. DMTL
2. Pressure Pipe
3. Charcoal canister
4. Breather Pipe
5. Evaporation Line
6. Fuel Fill Line
7. Fuel Tank
8. Fuel Tank Vent Line

## Fuel System

In order to meet the Zero Evaporative Emission requirement, the fuel system was completely revised. The fuel tank, tank filler neck, charcoal canister, fuel rail and tank ventilation valve are all made of stainless steel.

When perform repairs on the fuel system, it is imperative that all fitting remain clean and that the proper tightening torques are observed.

The fuel tank is manufactured of high grade steel and completely coated to meet the requirements of a minimum durability of 15 years.

The fuel tank can be exchanged only as a complete unit.

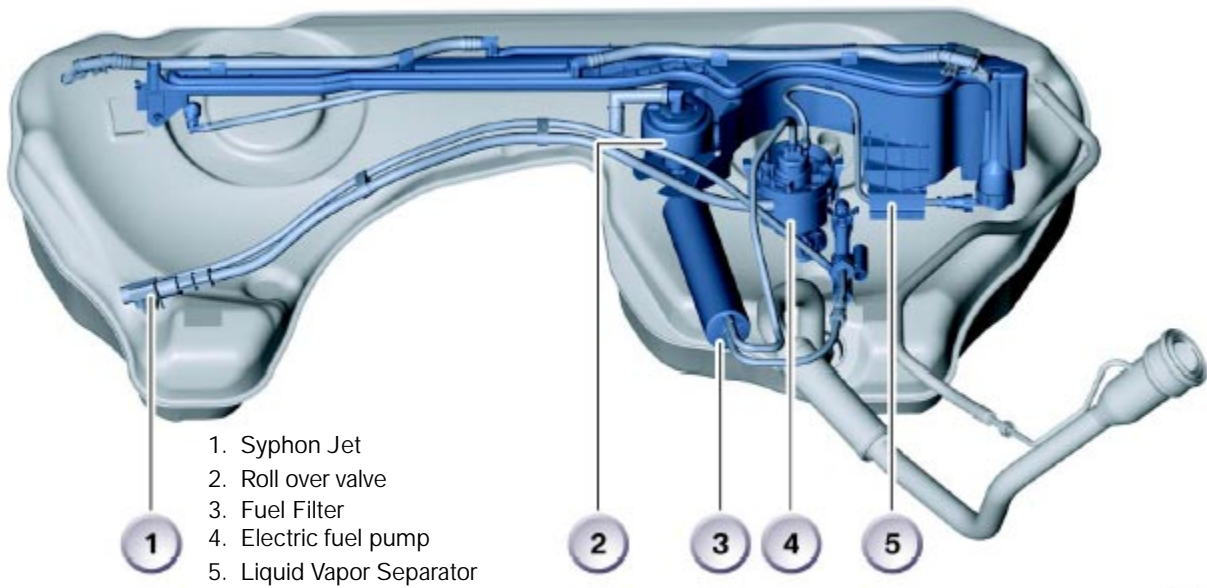
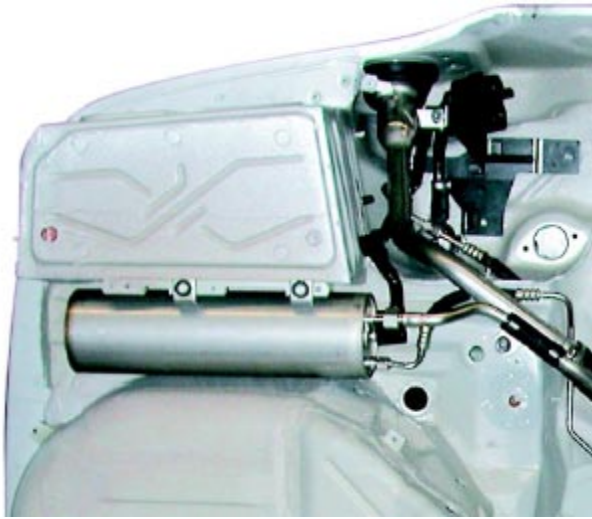

1. Syphon Jet
2. Roll over valve
3. Fuel Filter
4. Electric fuel pump
5. Liquid Vapor Separator

---

## Cooling System

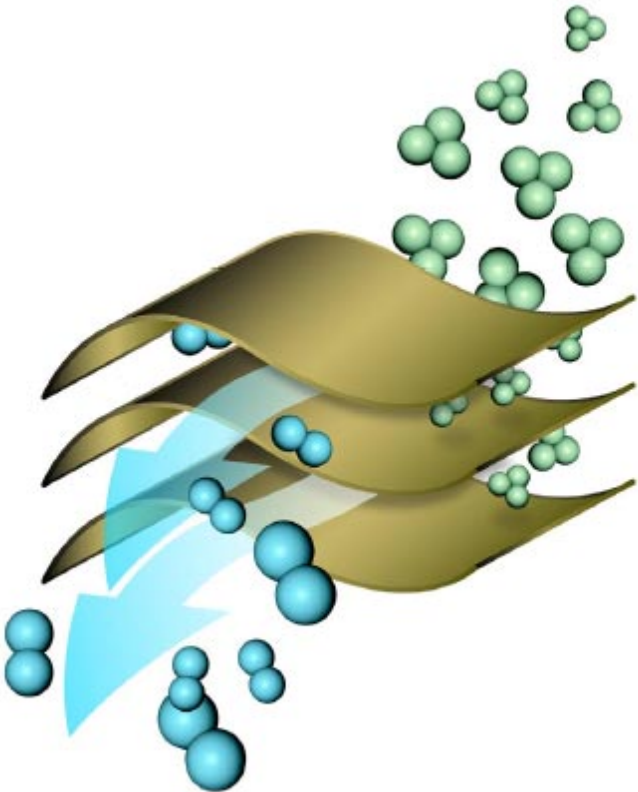

The radiator of the E46 SULEV looks similar to the standard E46 radiator.

The surface of the cooling fins are coated with a special "PremAir" coating.

The coating consists of multiple porous layers of a catalytic surface. The task of the catalyst coating is to convert Ozone into Oxygen.



---

## System Monitoring

Within the framework of OBD II, certain components/systems must be monitored once per driving cycle while other control systems (e.g. misfire detection) must be monitored permanently. **A "driving cycle" consists of engine startup, vehicle operation (exceeding of starting speed), coasting and engine stopping.**

### Permanent Monitoring

Permanently monitored systems are monitored according to temperature immediately after startup. In the event of malfunctions (e.g. oxygen sensor), the Malfunction Indicator Light will illuminate immediately.

The following are monitored permanently:

- Misfire Detection
- Fuel System (duration of injection)
- All emission related electrical circuits, components and systems of the ECM, TCM and EML (if equipped).

### Cyclic Monitoring

Systems monitored once per driving cycle will only result in a fault being registered after the corresponding operating conditions have been completed. Therefore, there is no possibility for checking when the engine is started up briefly and then shut down.

The following are monitored once per driving cycle:

- Oxygen Sensor Function
- Secondary Air Injection System
- Catalytic Converter Function (efficiency)
- Evaporative Vapor Recovery System

**Due to the complexity involved in meeting the test criteria within the defined driving cycle, all tests may not be completed within one "customer driving cycle". The test can be successfully completed within the defined criteria, however customer driving styles may differ and therefore may not always monitor all involved components/systems in one "trip".**

## Drive Cycle

The following diagram shows how a drive cycle is set (test drive) in order for all the systems to be monitored once. The test conditions can be created in any desired order after startup.

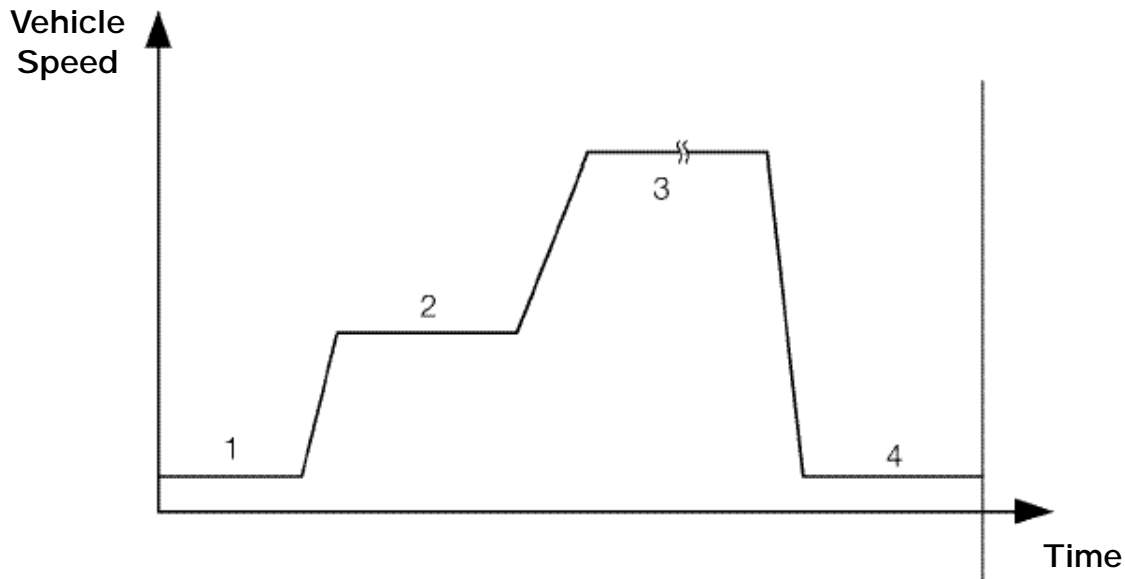

### Example of a Drive Cycle for Completing all OBD II Relevant Checks

1. Engine cold start, idling, approximately 3 minutes. Evaluated:
  - Secondary Air System
  - Evaporative Leak Detection (LDP Equipped Vehicles)
2. Constant driving at 20 to 30 MPH, approximately 4 minutes. Evaluated:
  - Oxygen Sensors - Achieved "Closed Loop" Operation
  - Oxygen Sensors - Response Time and Switching Time (Control Frequency)
3. Constant driving at 40 to 60 MPH, approximately 15 minutes (sufficient vehicle coasting phases included). Evaluated:
  - Catalytic Converter Efficiency
  - Oxygen Sensors - Response Time and Switching Time (Control Frequency)
4. Engine idling, approximately 5 minutes. Evaluated:
  - Tank-Leak Diagnosis (DM TL Equipped Vehicles after KL 15 is switched OFF)

### NOTE: The diagnostic sequence illustrated above will be interrupted if:

- The engine speed exceeds 3000 RPM
- Large fluctuations in the accelerator pedal position.
- The driving speed exceeds 60 MPH

The “**Malfunction Indicator Light**” ( MIL) will be illuminated under the following conditions:

- Upon the completion of the **next consecutive driving cycle** where the previously faulted system is monitored again and the emissions relevant fault is again present.
- Immediately if a “Catalyst Damaging” fault occurs (Misfire Detection).

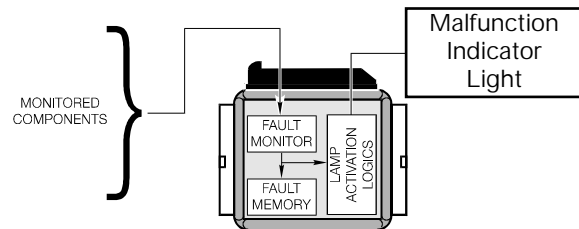

The illumination of the light is performed in accordance with the Federal Test Procedure (FTP) which requires the lamp to be illuminated when:

- A malfunction of a component that can affect the emission performance of the vehicle occurs and causes emissions to exceed 1.5 times the standards required by the (FTP).
- Manufacturer-defined specifications are exceeded.
- An implausible input signal is generated.
- Catalyst deterioration causes HC-emissions to exceed a limit equivalent to 1.5 times the standard (FTP).
- Misfire faults occur.
- A leak is detected in the evaporative system, or “purging” is defective.
- ECM fails to enter closed-loop oxygen sensor control operation within a specified time interval.
- Engine control or automatic transmission control enters a “limp home” operating mode.
- Ignition is on (KL15) position before cranking = **Bulb Check Function**.

Within the BMW system the illumination of the Malfunction Indicator Light is performed in accordance with the regulations set forth in CARB mail-out 1968.1 and as demonstrated via the Federal Test Procedure (FTP). The following page provides several examples of when and how the Malfunction Indicator Light is illuminated based on the “customer drive cycle”.

TEXT NO.	DRIVE CYCLE # 1			DRIVE CYCLE # 2			DRIVE CYCLE # 3			DRIVE CYCLE # 4			DRIVE CYCLE # 5			* DRIVE CYCLE # 43		
	FUNCTION CHECKED	FAULT CODE SET	MIL STATUS CHECK ENGINE	FUNCTION CHECKED	FAULT CODE SET	MIL STATUS CHECK ENGINE	FUNCTION CHECKED	FAULT CODE SET	MIL STATUS CHECK ENGINE	FUNCTION CHECKED	FAULT CODE SET	MIL STATUS CHECK ENGINE	FUNCTION CHECKED	FAULT CODE SET	MIL STATUS CHECK ENGINE	FUNCTION CHECKED	FAULT CODE SET	MIL STATUS CHECK ENGINE
1.	YES	YES	OFF															
2.	YES	YES	OFF	YES	YES	ON												
3.	YES	YES	OFF	NO	NO	OFF	YES	YES	ON									
4.	YES	YES	OFF	YES	NO	OFF	YES	NO	OFF	YES	YES	OFF	YES	YES	ON			
5.	YES	YES	OFF	YES	YES	ON	YES	NO	ON	YES	NO	ON	YES	NO	OFF			
6.	YES	YES	OFF	YES	YES	ON	YES	NO	ON	YES	NO	ON	YES	NO	OFF	YES	NO	OFF
																YES	FAULT CODE ERASED	OFF

1. A fault code is stored within the ECM upon the first occurrence of a fault in the system being checked.
2. The "Malfunction Indicator Light" will not be illuminated until the completion of the second consecutive "customer driving cycle" where the previously faulted system is again monitored and a fault is still present or a catalyst damaging fault has occurred.
3. If the second drive cycle was not complete and the specific function was not checked as shown in the example, the ECM counts the third drive cycle as the "next consecutive" drive cycle. The "Malfunction Indicator Light" is illuminated if the function is checked and the fault is still present.
4. If there is an intermittent fault present and does not cause a fault to be set through multiple drive cycles, two complete consecutive drive cycles with the fault present are required for the "Malfunction Indicator Light" to be illuminated.
5. Once the "Malfunction Indicator Light" is illuminated it will remain illuminated unless the specific function has been checked without fault through three complete consecutive drive cycles.
6. The fault code will also be cleared from memory automatically if the specific function is checked through 40 consecutive drive cycles without the fault being detected or with the use of either the DIS, GT-1 or Scan tool.

**Note: In order to clear a catalyst damaging fault (see Misfire Detection) from memory, the condition must be evaluated for 80 consecutive cycles without the fault reoccurring.**

With the use of a universal scan tool, connected to the "OBD" DLC an SAE standardized DTC can be obtained, along with the condition associated with the illumination of the "Malfunction Indicator Light". Using the DISplus or GT-1, a fault code and the conditions associated with its setting can be obtained prior to the illumination of the "Malfunction Indicator Light".

## Readiness Code

The readiness code provides status (Yes/No) of the system having completed all the required monitoring functions or not. The readiness code is displayed **with an aftermarket Scan Tool or the DISplus/GT-1**. The code is a binary (1/0) indicating;

- 0 = Test Not Completed or Not Applicable - six cylinder vehicles (not ready - V8 and V12)
- 1 = Test Completed - six cylinder vehicles (ready - V8 and V12)

A "readiness code" must be stored after any clearing of fault memory or disconnection of the ECM. A readiness code of "0" will be stored (see below) after a complete diagnostic check of all components/systems, that can turn on the "Malfunction Indicator Light" is performed.

The readiness code was established to prevent anyone with an emissions related fault and a "Malfunction Indicator Light" on from disconnecting the battery or clearing the fault memory to manipulate the results of the emissions test procedure (IM 240).

Interpretation of the Readiness Code by the ECM(s) (SAE J1979)

The complete readiness code is equal to "one" byte (eight bits). Every bit represents one complete test and is displayed by the scan tool, as required by CARB/EPA. For example:

**0 = EGR Monitoring (=0, N/A with BMW)**

**1 = Oxygen Sensor Heater Monitoring**

**1 = Oxygen Sensor Monitoring**

**0 = Air Condition (=0, N/A with BMW)**

**1 = Secondary Air Delivery Monitoring**

**1 = Evaporative System Monitoring**

**0 = Catalyst Heating**

**1 = Catalyst Efficiency Monitoring**



Drive the car in such a manner that all tests listed above can be completed (refer to the drive cycle). When the complete "readiness code" equals "1" (ready) then all tests have been completed and the system has established its "readiness".

## Readiness Code using the DISplus/GT-1

The readiness code can be checked with the DISplus/GT-1. This is particularly helpful in verifying that "drive cycle" criteria was achieved.

**A repair can be confirmed before returning the vehicle to the customer by a successfully completed drive cycle.**

Using an MS43 system for example, the readiness code is found under **"Service Functions"**

- Drive
- Digital Motor Electronics
- Diagnostic Function

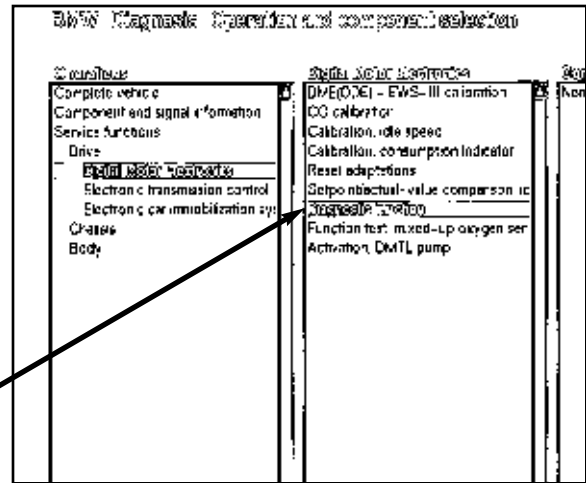

Select **"Own Test Plan"** → OBD II Readiness preconditions and description is shown:

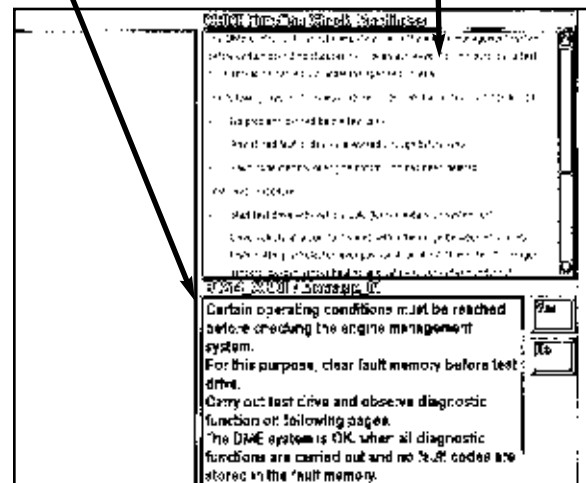
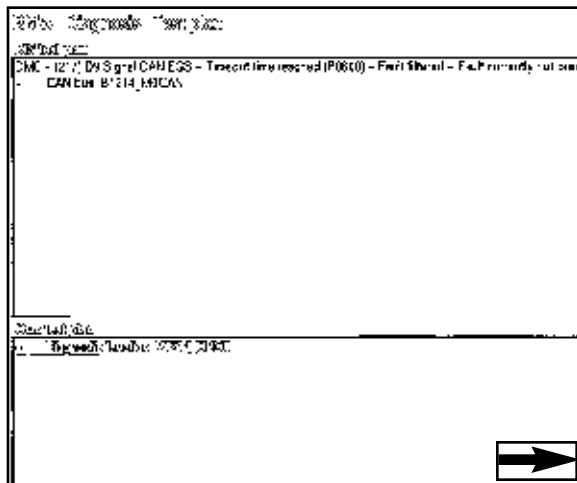

Examples of functions/components checked are shown below:

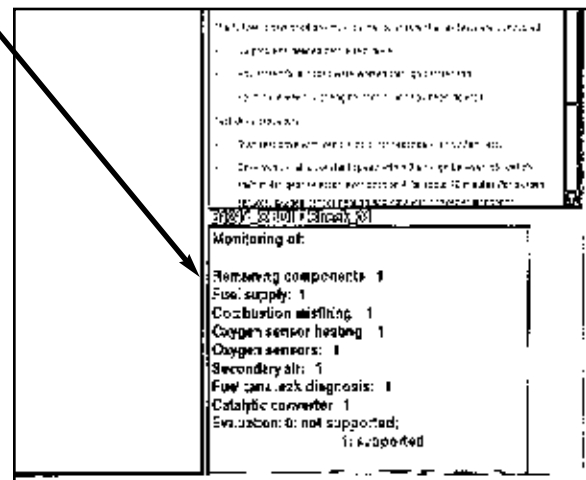
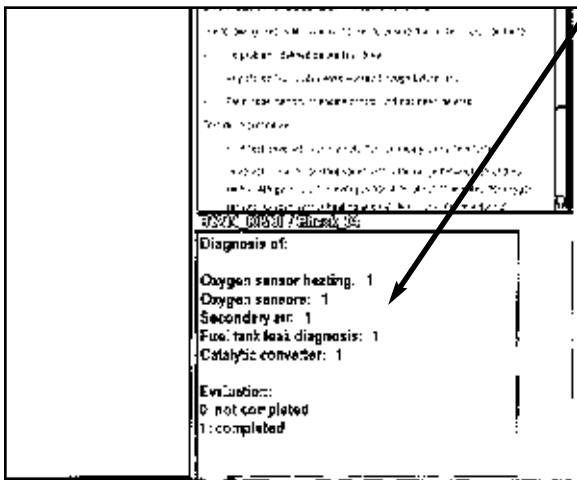

---

## OBD II Diagnostic Trouble Codes (DTC)

The Society of Automotive Engineers (SAE) established the Diagnostic Trouble Codes used for OBD II systems (SAE J2012). The DTC's are designed to be identified by their alpha/numeric structure. The SAE has designated the emission related DTC's to start with the letter "P" for Powertrain related systems, hence their nickname "P-code".

**For example:**

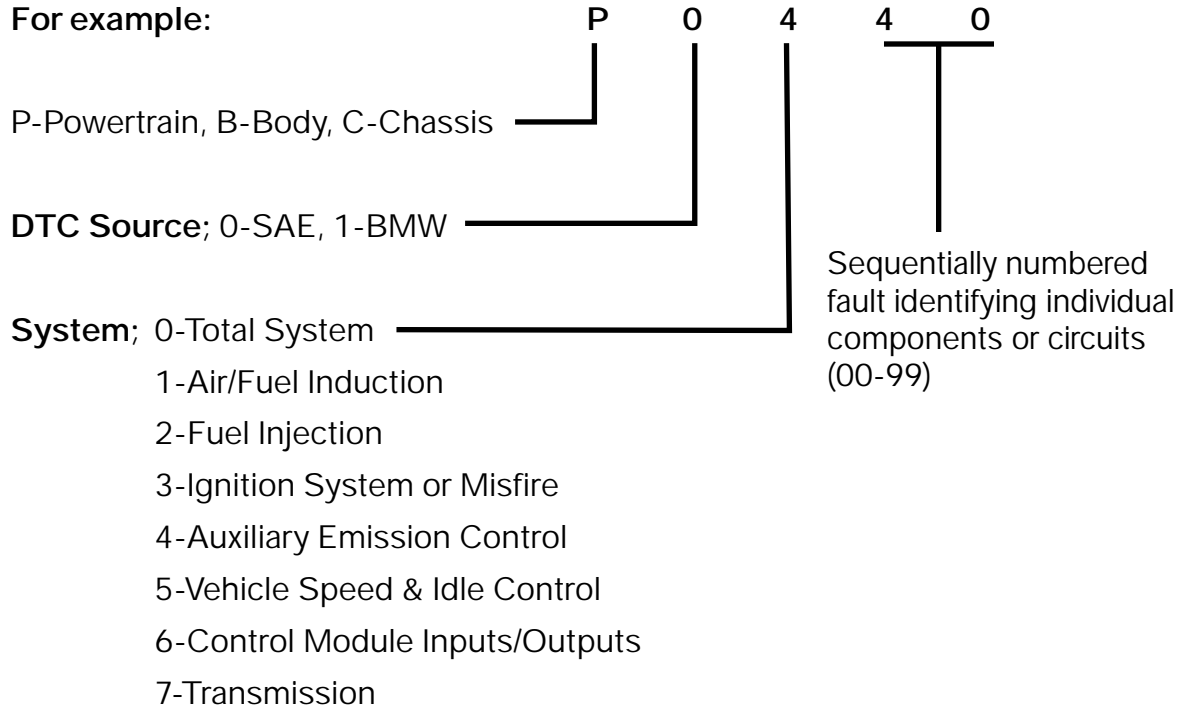

- DTC's are stored whenever the "Malfunction Indicator Light" is illuminated.
- A requirement of CARB/EPA is providing universal diagnostic access to DTC's via a standardized Diagnostic Link Connector (DLC) using a standardized tester (scan tool).
- DTC's only provide one set of environmental operating conditions when a fault is stored. This single "Freeze Frame" or snapshot refers to a block of the vehicles environmental conditions for a specific time when the fault first occurred. The information which is stored is defined by SAE and is limited in scope. This information may not even be specific to the type of fault.

## Scan Tool Connection

Starting with the 1995 750iL, soon after on all 1996 model year and later BMW vehicles, a separate OBD II Diagnostic Link Connector (DLC) was added.

The DLC provides access for an aftermarket scan tool to all emission related control systems:

- ECM - Engine Management Monitored Emissions Functions / Components
- TCM (AGS/EGS) - Transmission Control
- EML - Electronic Throttle Control

This diagnostic communication link uses the existing TXD II circuit in the vehicle through a separate circuit on the DLC when the 20 pin cap is installed.

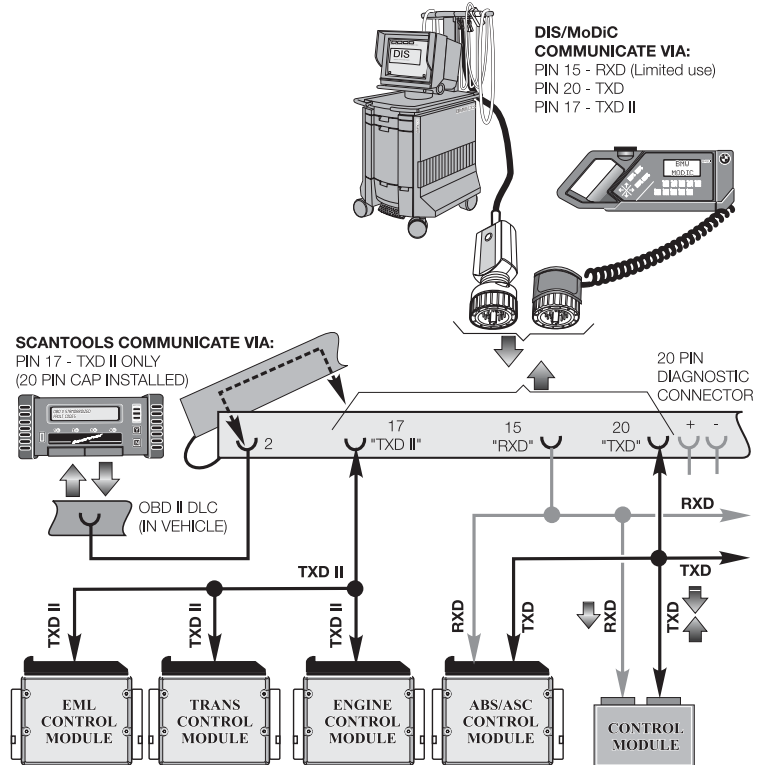

The DLC Connector bridging cap is marked "OBD II" and is found:

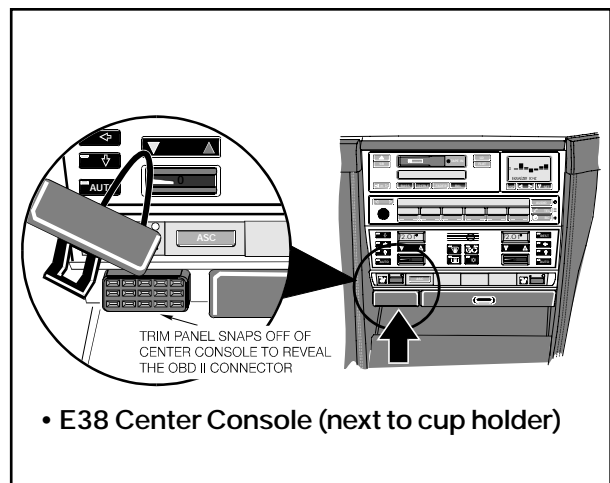
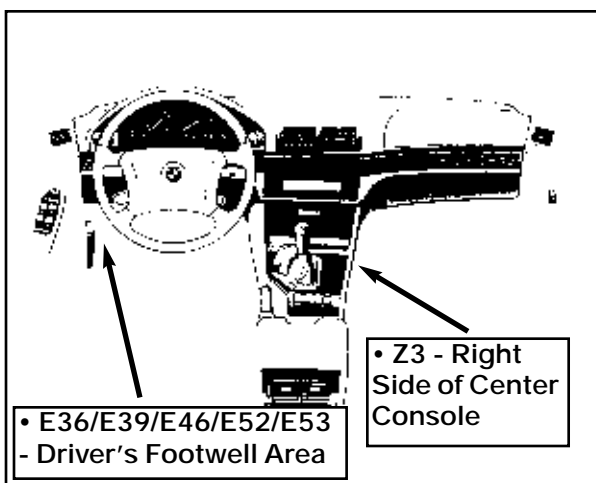

**NOTE:** E38 and older models have a cosmetic cover and a secured DLC cover.



---

## 20 Pin Diagnostic Socket Deletion

**Model and Production Date: E46 from 6/00**

**E39, E52, E53 from 9/00**

For model year 2001 the E39, E46 and E53 will eliminate the 20 pin diagnostic connector from the engine compartment. The 16 pin OBD II connector located inside the vehicle will be the only diagnosis port.

The E38 and Z3 will continue to use the 20 pin connector until the end of production.

The 16 pin OBD II connector has been in all BMWs since 1996 to comply with OBD regulations requiring a standardized diagnostic port.

Previously before 2001, only emissions relevant data could be extracted from the OBD II connector because it did not provide access to TXD (D-bus).

The TXD line is connected to pin 8 of the OBD II connector on vehicles without the 20 pin diagnostic connector.

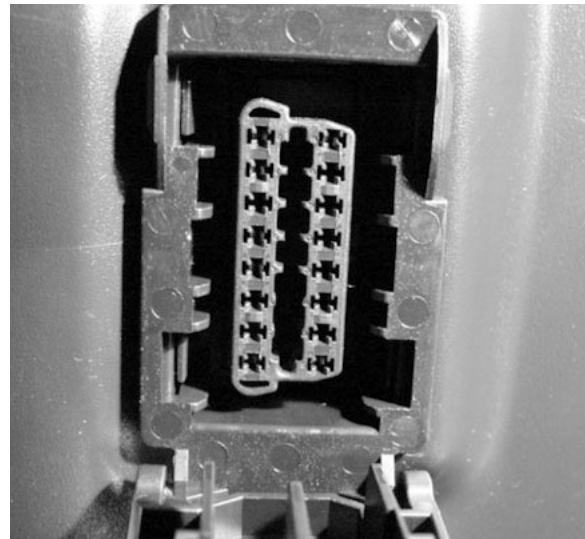

The cap to the OBD II connector contains a bridge that links KL 30 to TXD and TXD II. This is to protect the diagnostic circuit integrity and prevent erroneous faults from being logged.

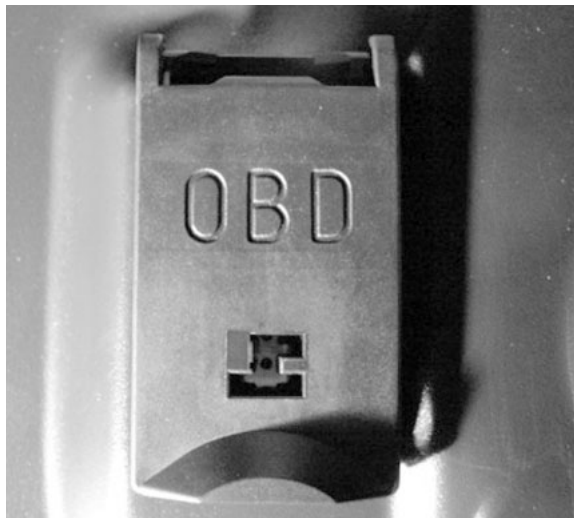

The OBD II connector is located in the driver's footwell to the left of the steering column for E39, E46 and E53 vehicles.

Special tool 61 4 300 is used to connect to the 20 pin diagnostic lead of the DIS until the introduction of the DISplus.

## Diagnostics via the OBD II Connector

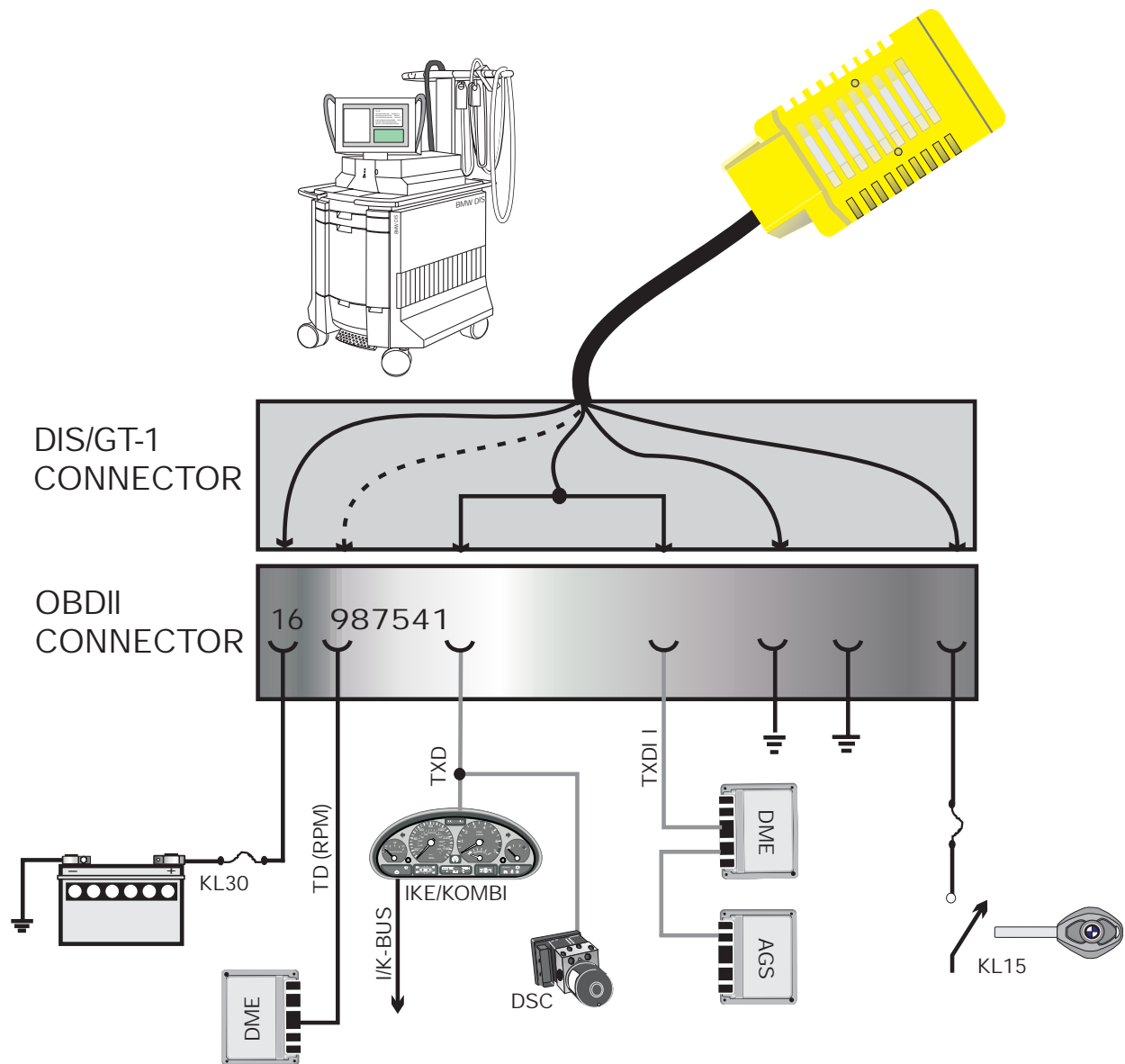

## BMW Fault Code (DISplus/GT-1)

- BMW Codes are stored as soon they occur even before the "Malfunction Indicator Light" comes on.
- BMW Codes are defined by BMW, Bosch and Siemens Engineers to provide greater detail to fault specific information.
- **Siemens systems** - one set from four fault specific environmental conditions is stored with the first fault occurrence. This information can change and is specific to each fault code to aid in diagnosing. A maximum of ten different faults containing four environmental conditions can be stored.
- **Bosch systems** - a maximum of four sets from three fault specific environmental conditions is stored within each fault code. This information can change and is specific to each fault code to aid in diagnosing. A maximum of ten different faults containing three environmental conditions can be stored.
- BMW Codes also store and displays a "time stamp" when the fault last occurred.
- A fault qualifier gives more specific detailed information about the type of fault (upper limit, lower limit, disconnection, plausibility, etc.).
- BMW Fault Codes will alert the Technician of the current fault status. He/she will be advised if the fault is actually still present, not currently present or intermittent.

The fault specific information is stored and accessible through DISplus/GT-1.

- BMW Fault Codes determine the diagnostic output for BMW DISplus/GT-1.

The screenshot displays a software interface for BMW diagnosis. At the top, there are four buttons: "Print", "Change", "End", and "Services". Below these is the title "BMW Diagnosis DIAGNOSIS REQUESTS". The main content area shows the following text:

**115 Hot-film air-mass flow**  
**Current type of Voltage Value**  
**The fault is not currently Detected 5**

**First fault detection 0h 24min ago**  
**Engine speed 600 rpm**  
**Coolant temperature 71 C**  
**Throttle-valve angle 4 degree**

At the bottom of the interface, there are several navigation buttons: a left arrow, "Function Selection", "Document", "Test Schedule", a right arrow, and "System".

---

## OBD II Fault Memory and Fault Codes

Within the framework of OBD II, a diagnosis of all emission-related components/functions must take place during driving. Faults will be stored and displayed if necessary. For this purpose, the ECM includes OBD II memory. The standardized P codes for malfunctions are stored in this memory. The memory can be read out with the DISplus/GT-1 or a Scantool.

## Emission Control Function Monitoring & Comprehensive Component Monitoring

OBD II regulations are based on section 1968.1 of Title 13, California Code of Regulations (CCR). The law set forth in section 1968.1 requires an increased scope of monitoring emission related control functions including:

- Catalyst Monitoring
- Heated Catalyst Monitoring (currently used on BMW 750iL vehicles)
- Misfire Monitoring
- Evaporative System Monitoring
- Secondary Air System Monitoring
- Air Conditioning System Refrigerant Monitoring (Not applicable for BMW vehicles)
- Fuel System Monitoring
- Oxygen Sensor Monitoring
- Exhaust Gas Recirculation (EGR) System Monitoring (Not applicable for BMW vehicles)
- Positive Crankcase Ventilation (PCV) System Monitoring (Not required at this time).
- Thermostat Monitoring (if equipped)

Monitoring these emission requirements is a function of the ECM which uses "data sets" while monitoring the conditions of the environment and the operation of the engine using existing input sensors and output actuators.

The data sets are programmed reference values the ECM refers to when a specific monitoring procedure is occurring. If the ECM cannot determine the environmental and/or engine operating conditions due to an impaired or missing signal, it will set a fault and illuminate the "Malfunction Indicator Light".

This input or control signal monitoring falls under another category called "**Comprehensive Component Monitoring**". The ECM must recognize the loss or impairment of the signal or component. The ECM determines a faulted signal or sensor via three conditions:

1. Signal or component shorted to ground.
2. Signal or component shorted to B+.
3. Signal or component lost (open circuit).

Specific fault codes are used to alert the diagnostician of these conditions.

---

## Review Questions

1. What is required to illuminate the "Malfunction Indicator" Light? \_\_\_\_\_  
\_\_\_\_\_  
\_\_\_\_\_  
\_\_\_\_\_

2. What are the definitions and differences between TLEV, LEV and ULEV?

TLEV = \_\_\_\_\_  
LEV = \_\_\_\_\_  
ULEV = \_\_\_\_\_

3. What is the OBD II Emission Compliance of a:

E46 M3 \_\_\_\_\_ 2001 3.0 Liter E46 \_\_\_\_\_ 1997 six cylinder E39 \_\_\_\_\_

4. List systems/components which are:

<u>Permanently Monitored</u>	<u>Monitored Once per Drive Cycle</u>
• _____	• _____
• _____	• _____
• _____	• _____
	• _____

5. Under what Operations "heading" (using the DISplus/GT-1) will you access the Readiness Code status for an MS43 equipped E46? \_\_\_\_\_

6. List the DLC connector locations in the following BMW vehicles:

E38 \_\_\_\_\_ Z3 \_\_\_\_\_  
Z8 \_\_\_\_\_ E46 \_\_\_\_\_

7. What are the three conditions an ECM uses to determine a faulted signal/sensor?

\_\_\_\_\_  
\_\_\_\_\_  
\_\_\_\_\_